

# TH 型磁芯 (Threaded Cores)

用途: IFT., RF., OSC., 驱动器, 检波器等用电感器

APPLICATIONS: INDUCTOR OF IFT.,RF.,OSC.,DRIVER,DETECTOR,ETC

ORDERING CODE:.

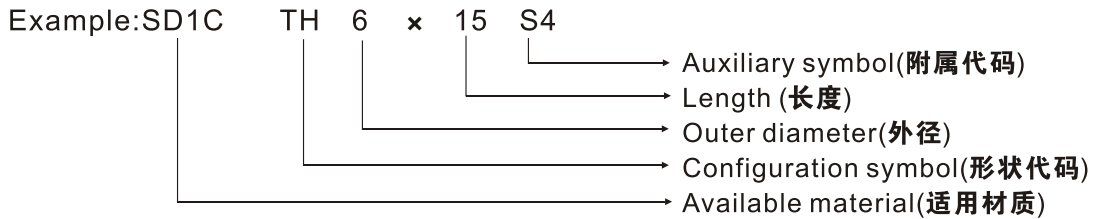

## CONFIGURATIONS:

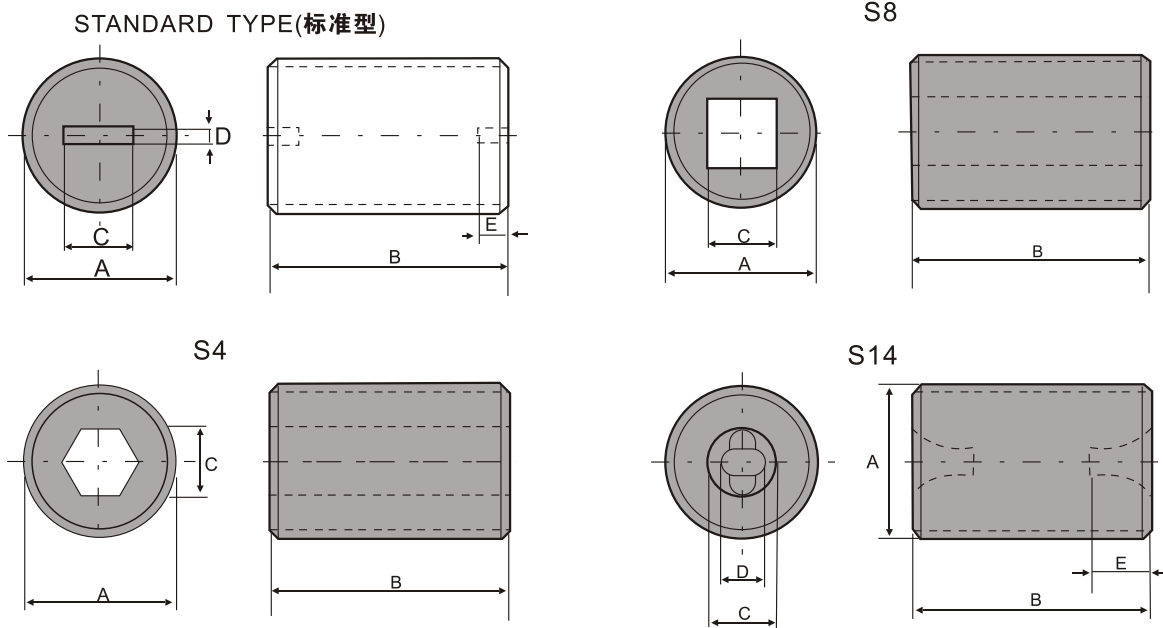

## Thread Shape

(Thread OC3)

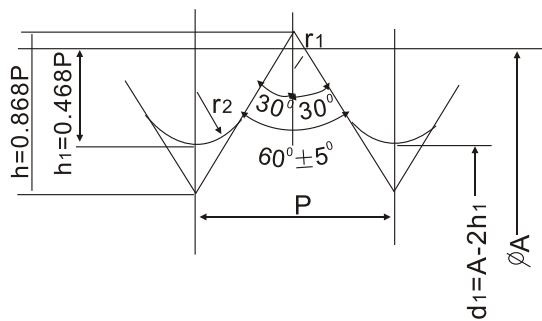

## DIMENSION SHAPES AND MAIN PRODUCTIONS:

UNIT:mm

P	h	hr	r1	r2
$0.50 \pm 0.03$	0.433	$0.23 \begin{smallmatrix} +0.10 \\ -0.05 \end{smallmatrix}$	$0.06 \pm 0.03$	$0.15 \pm 0.03$
$0.60 \pm 0.03$	0.520	$0.28 \begin{smallmatrix} +0.10 \\ -0.03 \end{smallmatrix}$	$0.07 \pm 0.03$	$0.17 \pm 0.03$
$0.75 \pm 0.03$	0.650	$0.35 \begin{smallmatrix} +0.14 \\ -0.03 \end{smallmatrix}$	$0.08 \pm 0.03$	$0.22 \pm 0.03$
$1.00 \pm 0.03$	0.866	$0.47 \begin{smallmatrix} +0.14 \\ -0.03 \end{smallmatrix}$	$0.11 \pm 0.03$	$0.29 \pm 0.03$

## DIMENSION OF MAIN PRODUCTIONS:

UNIT:mm

Ordering code	A	B	C	D	E
TH2.6 × 3	2.6 ± 0.03	3.0 ± 0.3	1.3 ± 0.15	0.3 ± 0.1	1.0 ± 0.2
TH3.18 × 5	3.18 ± 0.03	5.0 ± 0.3	1.3 ± 0.15	0.7 ± 0.1	1.2 ± 0.2
TH3.2 × 3.9	3.2 ± 0.03	3.9 ± 0.2	1.3 ± 0.15	0.7 ± 0.1	1.2 ± 0.2
TH3.2 × 5.5	3.2 ± 0.03	5.5 ± 0.3	1.3 ± 0.15	0.7 ± 0.1	1.2 ± 0.2
TH3.2 × 6	3.28 ± 0.03	6.0 ± 0.3	1.3 ± 0.15	0.7 ± 0.1	1.2 ± 0.2
TH3.66 × 8	3.66 ± 0.03	8.0 ± 0.3	1.5 ± 0.15	0.8 ± 0.1	1.2 ± 0.2
TH4 × 6	4.0 ± 0.03	6.0 ± 0.3	1.5 ± 0.15	0.8 ± 0.1	1.2 ± 0.2
TH5.85 × 8	5.85 ± 0.03	8.0 ± 0.3	2.4 ± 0.15	1.2 ± 0.1	1.25 ± 0.2
TH7.5 × 36s4	7.5 ± 0.03	36.0 ± 0.1	2.7 ± 0.1		
TH4.5 × 15s4	4.5 ± 0.03	15.0 ± 0.4	2.0 ± 0.07		
TH4.6 × 6s4	4.6 ± 0.03	6.0 ± 0.3	2.0 ± 0.07		
TH4.6 × 9.53s4	4.6 ± 0.03	9.53 ± 0.3	2.0 ± 0.07		
TH6 × 20s4	6.0 ± 0.03	20.0 ± 0.6	2.7 ± 0.1		
TH6.18 × 19s4	6.18 ± 0.03	19.0 ± 0.6	2.7 ± 0.1		
TH6.18 × 25s4	6.18 ± 0.03	25.0 ± 0.8	2.7 ± 0.15		
TH6.25 × 28s4	6.25 ± 0.03	28.0 ± 0.8	2.7 ± 0.15		
TH6.3 × 25.4s4	6.3 ± 0.03	25.4 ± 0.8	2.7 ± 0.15		
TH3.2 × 5s8	3.2 ± 0.03	5.0 ± 0.3	1.0 ± 0.07		
TH3.7 × 8s8	3.7 ± 0.03	8.0 ± 0.3	1.5 ± 0.1		
TH4.6 × 6s8	4.6 ± 0.03	6.0 ± 0.3	1.5 ± 0.1		
TH3.2 × 5s14	3.2 ± 0.03	5.0 ± 0.3	1.6 ± 0.15	0.9 ± 0.1	1.0 ± 0.2
TH3.66 × 8s14	3.66 ± 0.03	8.0 ± 0.3	1.6 ± 0.15	0.85 ± 0.1	1.2 ± 0.2
TH4.6 × 8s14	4.6 ± 0.03	8.0 ± 0.3	2.6 ± 0.15	1.0 ± 0.1	1.7 ± 0.2

\* “B”尺寸可在合理范围内调整。